

INSIDERS MERRY KARNOWSKY



One of the most important things I have learned over the past 10 years is that no matter how many art reviews I read or texts books I comb through, I always come back to the same place: where I started. We are living in a golden age of art, which none of us should waste another single moment questioning. And it would behoove us to look back on our own personal history and what we have and what we are creating, rather than seeking other sources

to validate our endeavors.

Because of this, remember to cherish every—single—moment.

I opened my gallery a decade ago in 1997, with a phone call to Todd and Kathy Schorr, brilliant artists and friends, who said, "Congratulations, you deserve it. Of course we'll show with you," upon the announcement of my opening. The gallery debut with an astounding

exhibition sold out before the doors opened, allowing me to continue with what was at the time only a spark of possibility. My next call was to Kent Williams, another good friend and artist whose work I have personally collected for longer than I have owned my gallery. His art continues to represent an important cornerstone of the gallery's aesthetic: a representation of complex, narrative work that pushes beyond convention. Then in 2000, a young

woman by the name of Camille Rose Garcia sent me a letter with a hand-glittered paper doll that I have saved to this day. Seven sold-out shows later (and high-profile collectors who now promise to get me into A List parties if they can get on her waiting list) is an indication of art stardom at its finest. That was also the same year I began showing Shepard Fairey, an artist whose impact needs no explanation.



Since that time, and in subsequent years, other artists have entered my scope and become apart of what I hope is more than just a gallery. Richard Colman and Dalek, who spent five days and nights (along with a couple bottles of rum) painting murals of Space Monkeys, bears, and hairy men in underpants for their first show, now have huge collector bases and fans worldwide. Jim Houser, despite great tragedy, has created some of the

most poetic and lyrical installations and paintings humanly imaginable. There is FriendsWithYou's Arturo Sandoval III and Sam Borkson, whose parade at Art Basel Miami made the front page of the *New York Times* and ArtNet, despite being only a few years old on the gallery circuit. Also consider Dean Karr, whose raw vision and talent propelled him to the heights of success in photography, video, and film. And Becca, who was there at

the beginning, and in my mind will always be ahead of her time. The list goes on and on.

Through it all the point is this: Memento Gaudere Semper. My son (photographed here) exemplifies this sentiment perfectly, with a simple and amusing gesture of rebellion, captivating the spirit I hope Merry Karnowsky Gallery has represented and will continue to embody. What counts is now. Soak

in every moment. And always dare.
—Merry Karnowsky

Merry Karnowsky Gallery
170 South La Brea Avenue
Los Angeles, California
323.933.4408
Mkgallery.com

Photo by igofbeverlyhills
Art Direction by Gregory Teodori

DECADE

MERRY KARNOWSKY GALLERY

10TH YEAR ANNIVERSARY EXHIBITION

June 30 - July 28

Opening Reception: Saturday June 30, 8-11pm

Richard Colman
Dalek
Shepard Fairey
FriendsWithYou
Camille Rose Garcia
Steven Gilmore
Jim Houser
Dean Karr
Junko Mizuno
Aiko Nakagawa
Mark Ryden
Kathy Staico Schorr
Todd Schorr
Miss Van
Eric White
Kent Williams
Robert Williams
Suzanne Williams



Merry Karnowsky Gallery 170 South La Brea Avenue
Los Angeles, California 90036 P.323.933.4408 www.mkgallery.com

MISS VAN | JUNKO MIZUNO | AIKO NAKAGAWA
March 10 - April 7

RICHARD COLMAN
Solo Exhibition April 21 - May 19

TRAGIC KINGDOM
Solo exhibition for Camille Rose Garcia
at The San Jose Museum of Art, San Jose, California
May 13 - September 23

MERRY KARNOWSKY GALLERY
DECADE: 10TH YEAR ANIVERSARY EXHIBITION
June 30 - July 28

DALEK
Solo Exhibition August 4 - September 1

KENT WILLIAMS
Solo Exhibition September 8 - October 6

CAMILLE ROSE GARCIA
Solo Exhibition October 20 - November 17

SHEPARD FAIREY
Solo Exhibition December 1 - January 14, 2008

MERRY KARNOWSKY GALLERY 170 South La Brea Avenue
Los Angeles, California 90036 mkgallery@mindspring.com
www.mkgallery.com voice 323.933.4408 fax 323.935.4406



C A R
+ B A C
A S H



www.BanksyP



PORT CONTROLLERS

HAM™

unked.com™



about US²

SWERVE





SWERVE veers around the expected. At least where architectural and furniture design solutions are concerned. It's an attribute that's ideally suited to a world of new economies and business practices. Shape and scale shifting is a matter of course. Flexibility comes in mighty handy.

These contemporary ideas stem from an environment that's alive with fresh ideas and resources. Call it a design factory that creatively responds to aspects of the modern workplace—functionality, material, workability, and color. SWERVE imbues a project with new materials and technology, while maintaining craft standards that you may have thought were lost in the dust of the digital. Swerve, however, makes full, efficient use of high quality high tech tools to mass customize, and expediently realize personalized pieces in made-to-order quantities.

SWERVE, it so happens, is one of the most technically sophisticated, well-equipped, full-service shops in Northern California. True to the maverick spirit of the West, Swerve is state of the art. Unique designs are honed here using Unigraphics, a 3-D modeling machining program, which, not surprisingly, is digitally nimble enough to easily and thoroughly implement subtle—and not so subtle—changes in style and size. Your shifting design needs are easily accommodated.

Though the designs are refined on the computer screen, SWERVE has something that can turn a digital file into something you can sit on in no time. The massive CNC "super machine," a five-axis, computerized amalgamation of automated routers, drills and other tools that can quickly realize a prototype of a just-designed piece in real life scale. If you like what you see, it can go directly into production. You can fit your whole company with dozens of workstation docks that are the antithesis of standard issue. But then again, you could just trick out the CEO's chambers with something that's yours alone.

Steer clear of the usual:-

CUSTOMIZATION



X-GruppoTM

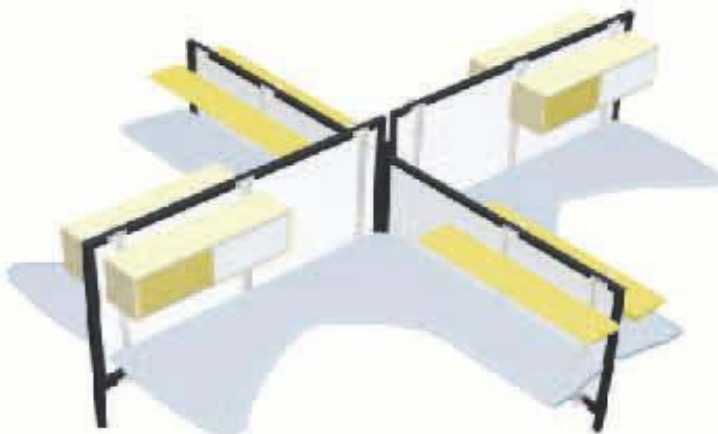

X-configuration for four adjacent working environments. They're luxurious full-service areas, with adjustable desk and shelving height. You'll work closely together, but with lots of independence – state of the art materials enhance visual and aural privacy. X marks a very productive spot.

Standardly:

Monolithic top finished in semi-matte plasticolor enamel • All color options available • Super duty frame with dark grey crinkle powdercoat finish • 4' shelf • Polycarbonate panels • Stainless steel leveling feet • Edge bumper • Adjustable height on all worktops and shelves • Cable Management

Options:

Privacy screen • LockBox • Casters • Tasklight brackets • MemoBoard • Additional shelves • Cable wrap • Need something you don't see – we'll make it.

MASS CUSTOMIZATION

Adjustable Brackets For Table Height and Flexibility

Lamp Bracket

Adjustable Stainless Steel Leveling Feet

Swerve X-Grouppo
Evolve Software, Emeryville, California.

Photography: Ethan Kaplan

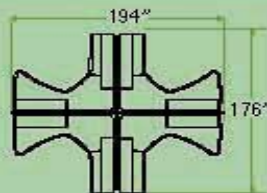
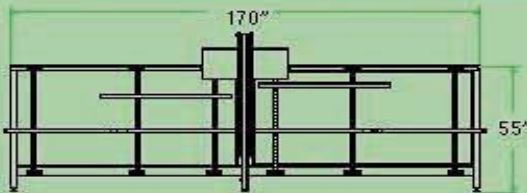

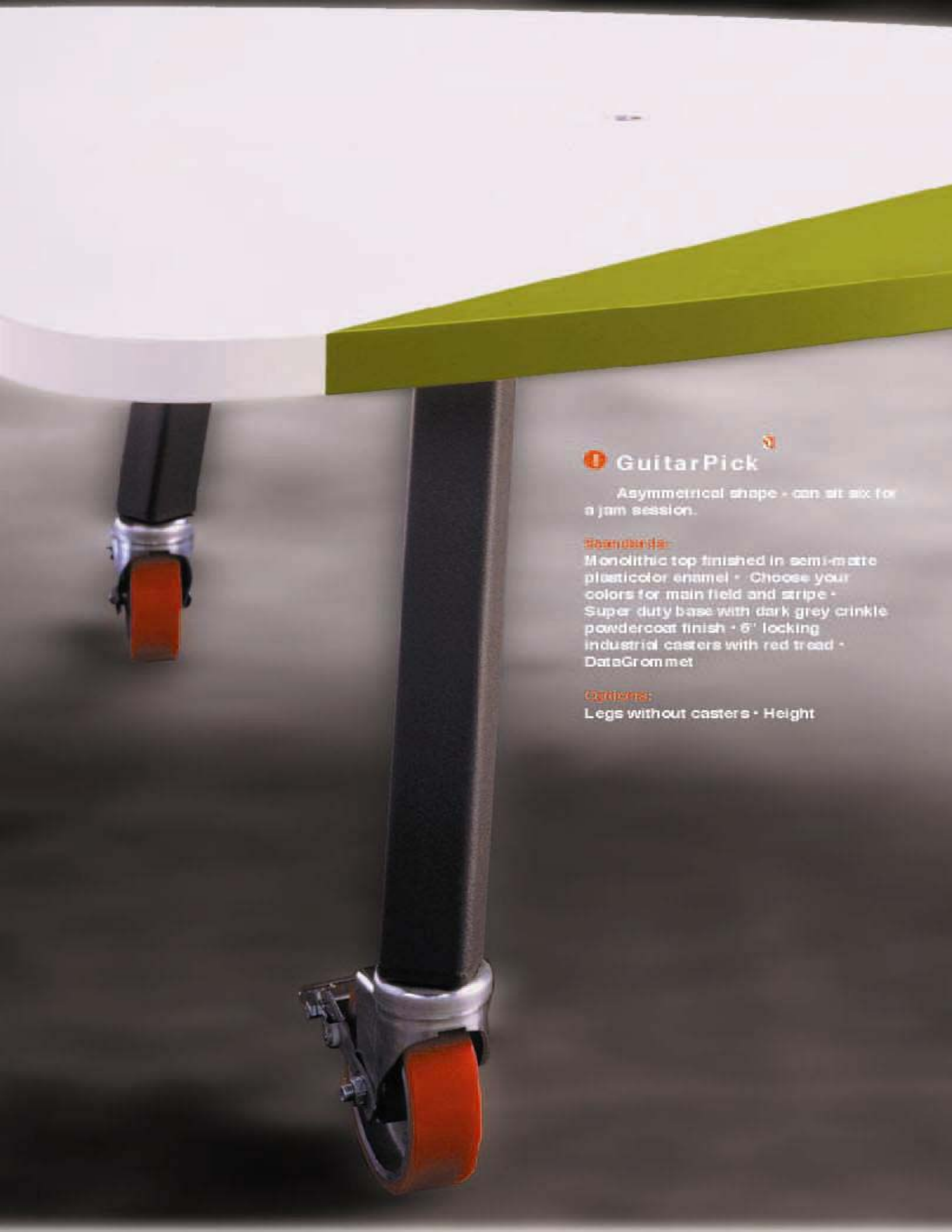

GuitarPick

Asymmetrical shape - can sit six for a jam session.

Standard:

Monolithic top finished in semi-matte plasticolor enamel - Choose your colors for main field and stripe - Super duty base with dark grey crinkle powdercoat finish - 6" locking industrial casters with red tread - DataGrommet

Options:

Legs without casters - Height

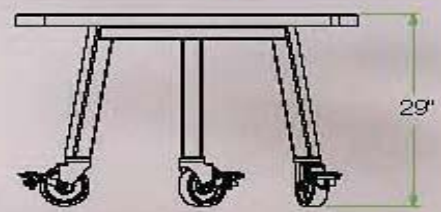
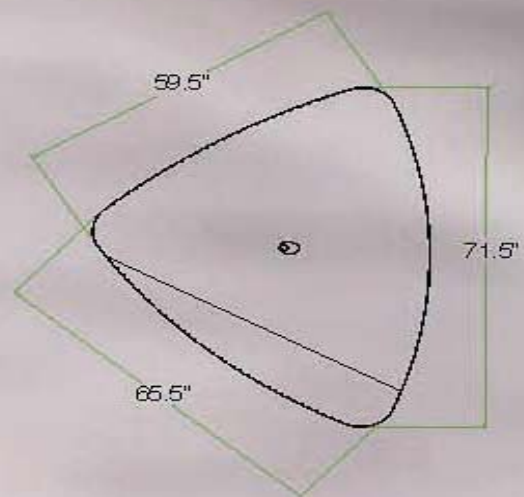
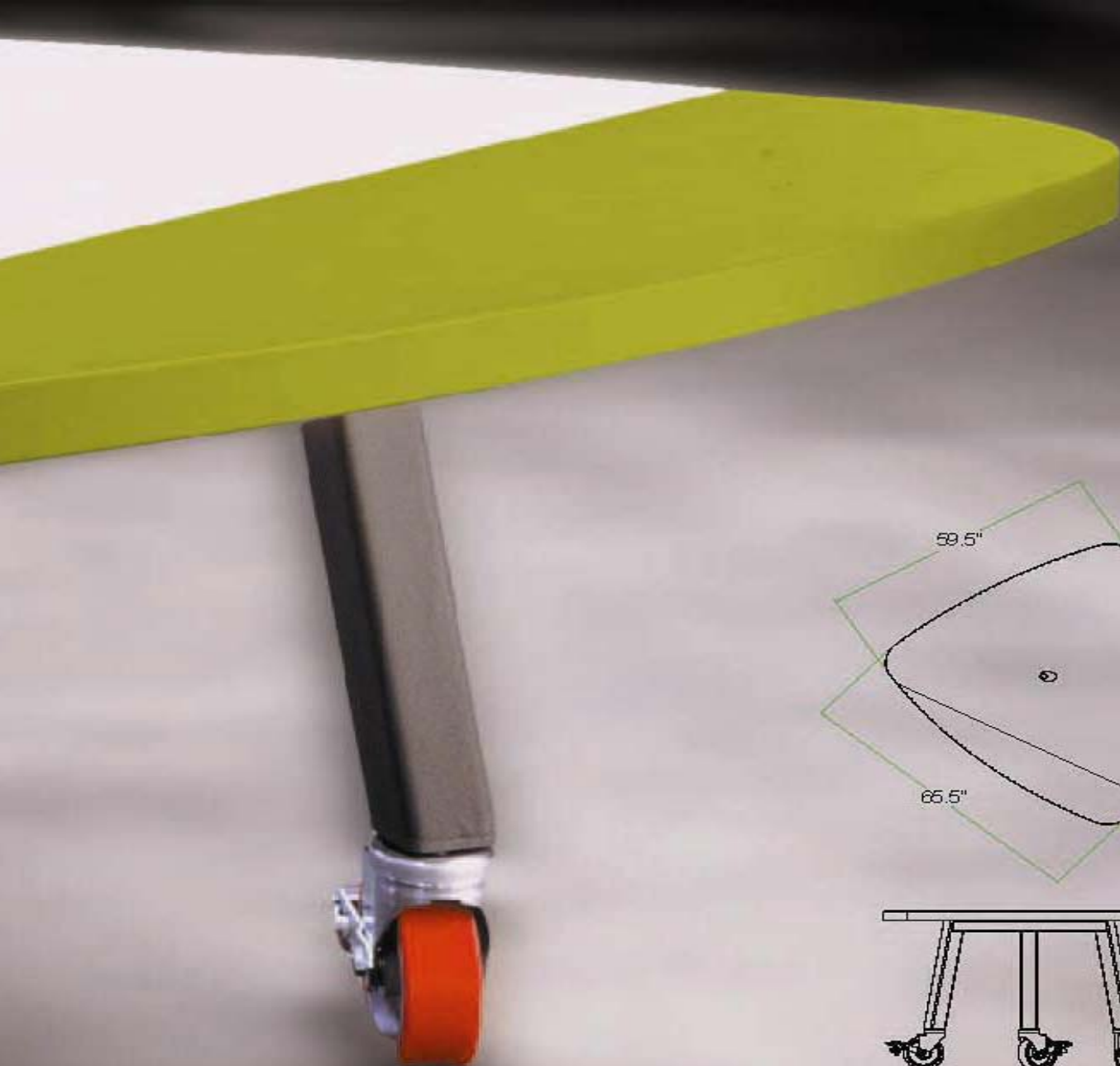

MiniPick

Smaller than the guitar pick, perfect for a trio. Docks into our workstations for a quick pull-away conference top.

Standards:
 Monolithic top finished in semi-matte plastic or enamel • Choose your colors for main field and stripe • Super duty base with dark grey crinkle powdercoat finish • 6" locking industrial casters with red tread.

Options:
 DataGrommet • Legs without casters • Height • Pattern

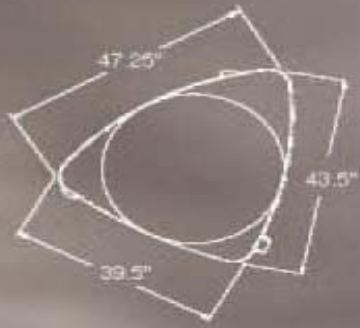
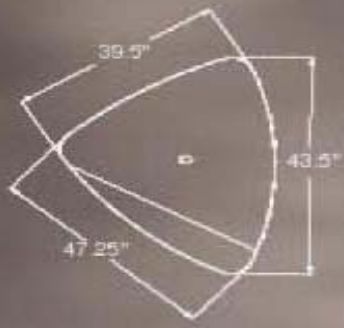

CNC Machine

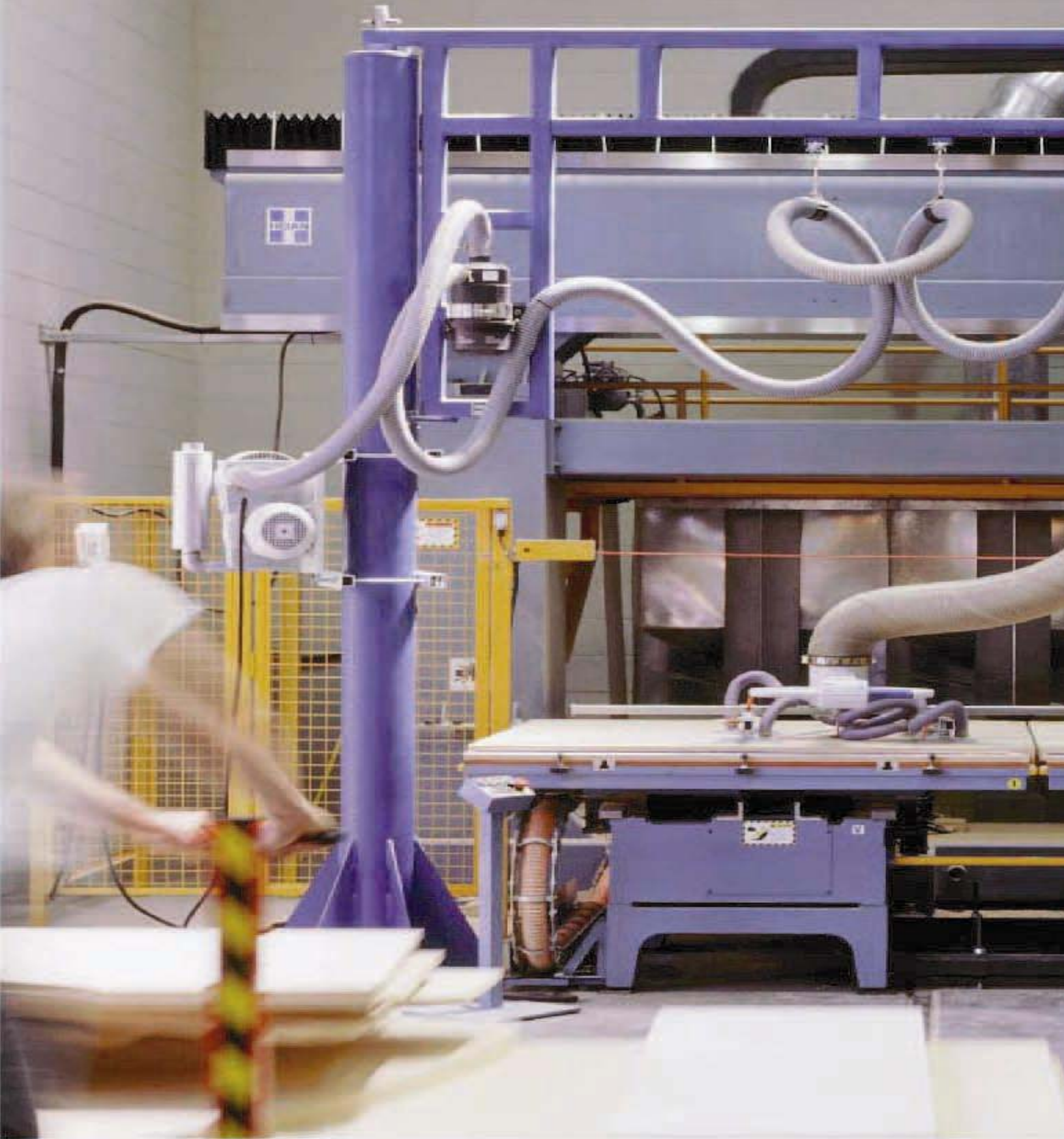



SWERVE links design and manufacturing sawy with a fantastic custom-built mixture of hardware and software. The CNC Machine (Computer Numeric Control) is driven by Unigraphics, a program developed by McDonnell Douglas to design products such as the Space Shuttle. It's a five-axis, state of the art high-speed machining tool that can take a digital CAD/CAM-plotted design and turn it into finished product in no time flat. The automated CNC can efficiently carve, say, a wood tabletop exactly tailored to your boardroom's particular measurements. But don't let that limit your imagination. The CNC can also swiftly create complicated three-dimensional shapes.

This is one of a very few such machines on the West, and it gives SWERVE precise, sophisticated and unusually flexible manufacturing ability. The CNC, customized for furniture-making efficiency, truly lives up to its reputation as a super machine :-

HAVING A WIDE RANGE OF EXPERIENCE AND EXPERTISE MAKES IT EASIER TO EXTEND INTO NEW AREAS. AS SOMETHING OF A DESIGN FACTORY WITH MAJOR EXPERIENCE IN FURNITURE DESIGN, ARCHITECTURE AND MANUFACTURING, SWERVE IS LIMBER ENOUGH TO DO JUST THAT. AND SO IS THE FURNITURE, WHICH IS SLEEK AND STURDY, EMPLOYING STRONG MATERIALS AND OFTEN BUILT ON WHEELS THAT EMBRACE THE IDEA OF MODULAR RECONFIGURATION AND FORWARD THINKING MOVEMENT



RoundTop



Versatile, easygoing, satisfyingly round. Have it around as an emergency workstation.

Standards:

Monolithic top finished in semi-matte plasticolor enamel • Choose your color • Super duty base with dark grey crinkle powdercoat finish • 6" locking industrial casters with red tread.

Options:

Legs without casters • Height • DataGrommet® so your cables can come through.

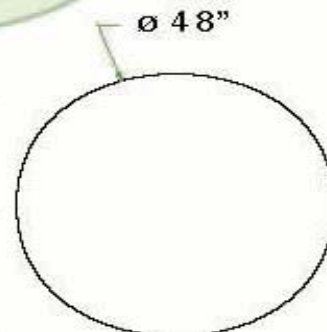
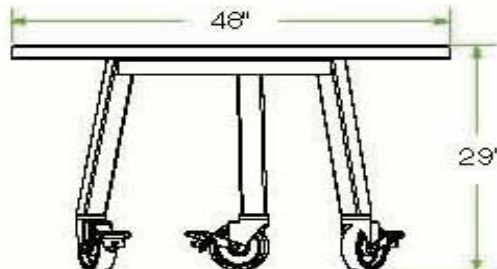

StudioTables

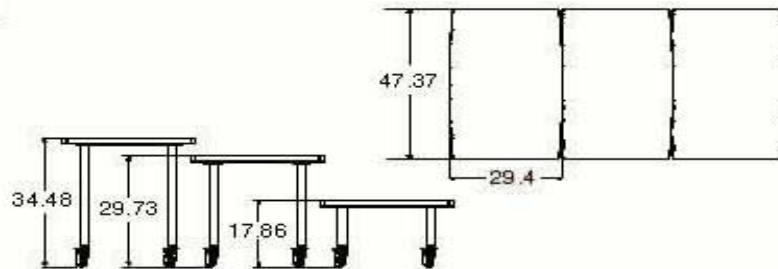

"The SWERVE studio tables by designer Michael Goldin offer three height options and multiple uses. The low table can act as a coffee table in a waiting area or as an indestructible work and play table for a child's room or nursery school. The medium height table makes a solid yet minimal desk, while the high 36" studio table stands at the right height for use as a drafting table or a mobile kitchen island. Tabletops are coated with a catalyzed conversion varnish for a durable matte-satin finish. They feature a heavy-gauge steel frame and oversized lockable casters for mobility. While many tables appropriate the clean look of industrial design, the SWERVE Studio Tables employ true industrial-grade materials and processes in construction and finishing. Fresh color, fluid lines and a playful sense of proportion add wit to their serious utility. Assembly required."

- Design Within Reach, www.dwr.com



Multiple uses - Children's play, coffee table, extra desk, drafting or kitchen cart.

Sold exclusively through Design Within Reach: 1800.944.2233, www.dwr.com

Standards:

Monolithic top finished in semi-matte plasticolor enamel • Choose your colors: NewGreen, Natural, Black • Super duty base with dark grey crinkle powdercoat finish • 4" double locking industrial grey casters • Assembly Required.



4Top



1 The little Big Top. 4 sides come together at groovy angles, 4 people can meet.

Specifications:
 Monolithic top finished in semi-matte plasticolor enamel • Choose your colors for main field and stripe • Super duty base with dark grey crinkle powdercoat finish • 6" locking industrial casters with red tread • DataGrommet so your cables come through • Beveled edges for style and comfort

Options:
 Legs without casters • Height

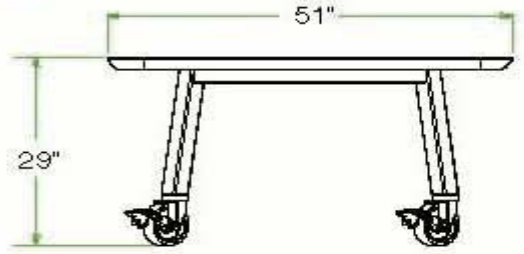

8Top

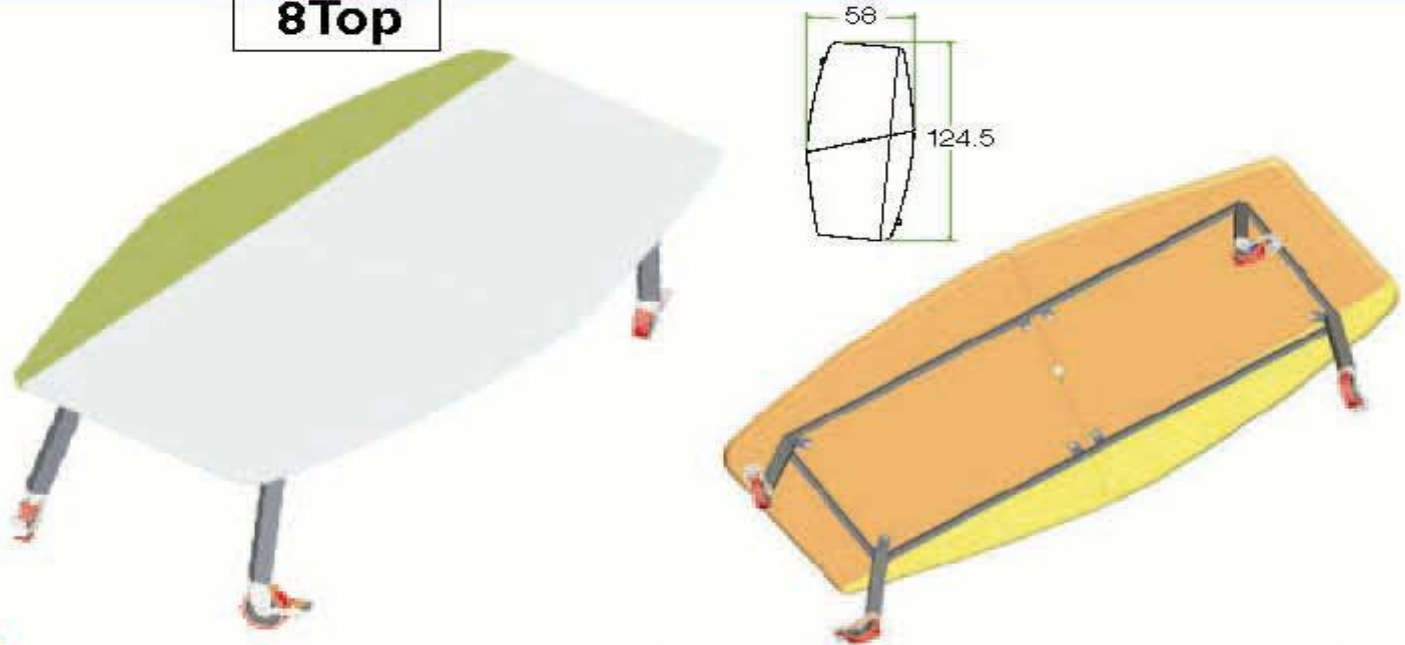

1 8 people can come to the 8 for 'maxin' and relaxin', or just cranking out the strategy for the next 18 months.

Specifications:
 Monolithic top finished in semi-matte plasticolor enamel • Choose your colors for main field and stripe • Super duty base with dark grey crinkle powdercoat finish • 6" locking industrial casters with red tread • DataGrommet so your cables come through • Beveled edges for style and comfort

Options:
 Legs without casters • Height

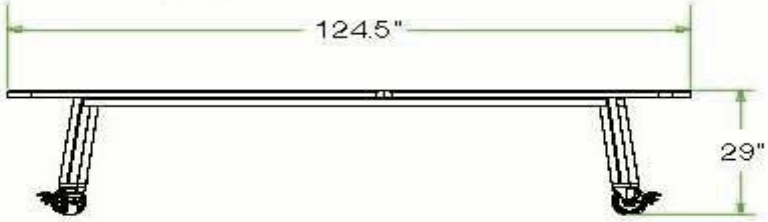

6Top

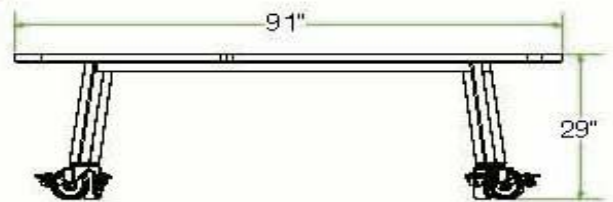
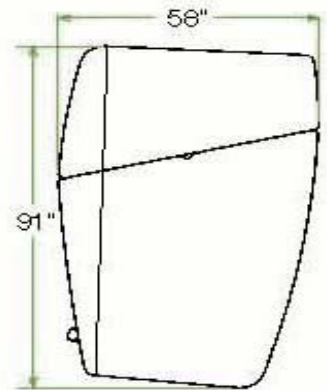

I Bigger than the 4Top, smaller than the 8Top, where 6 people can chill. Top is made up from 2 pieces for that line of distinction.

Standards:
Monolithic top finished in semi-matte plasticolor enamel • Choose your colors for main field and stripe • Super duty base with dark grey crinkle powdercoat finish • 6" locking industrial casters with red tread • DataGrommet[®] so your cables come through • Beveled edges for style and comfort

Options:
Legs without casters • Height

10Top

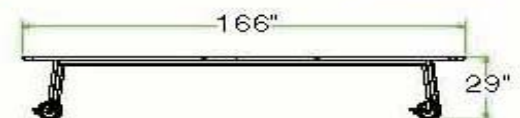
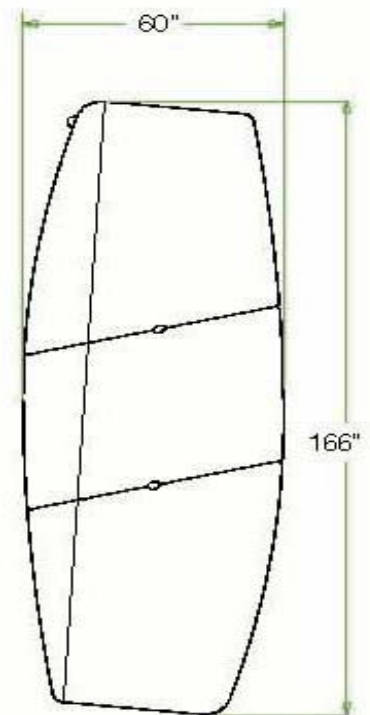
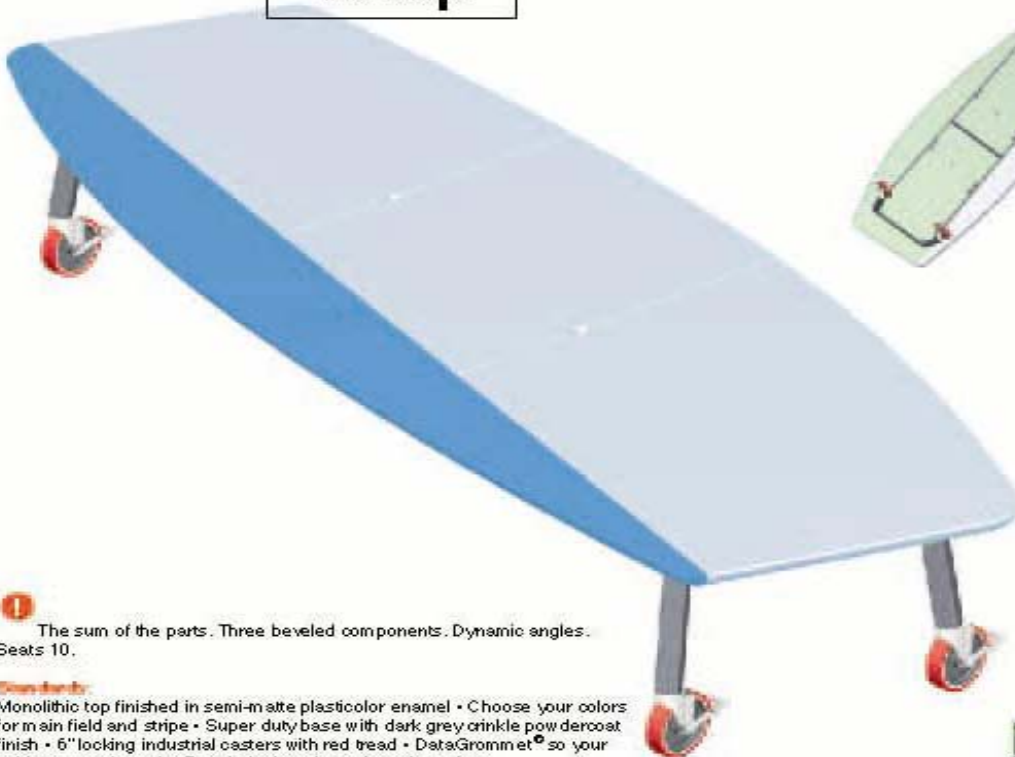

I The sum of the parts. Three beveled components. Dynamic angles. Seats 10.

Standards:
Monolithic top finished in semi-matte plasticolor enamel • Choose your colors for main field and stripe • Super duty base with dark grey crinkle powdercoat finish • 6" locking industrial casters with red tread • DataGrommet[®] so your cables come through • Beveled edges for style and comfort

Options:
Legs without casters • Height



T_Groupo

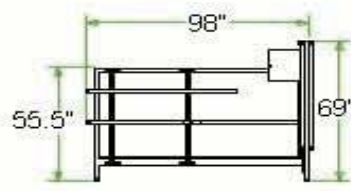
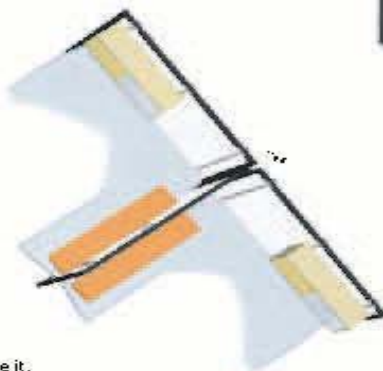
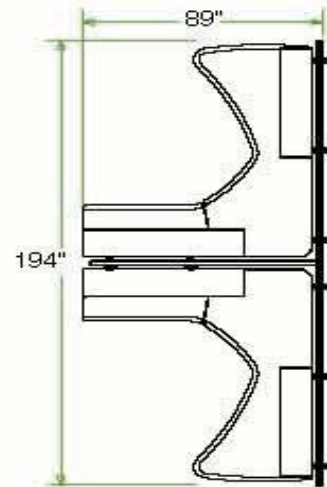

1 Luxurious yet space efficient work environments. Two private full-service areas with adjustable desk and shelving height. They may share a common wall, but there's nothing common going on here.

Standard: Monolithic top finished in semi-matte plasticolor enamel • All color options available • Super duty frame with dark grey crinkle powdercoat finish • 4" shelf • Polycarbonate panels • Stainless steel leveling feet • Edge bumper • Adjustable height on all worktops and shelves • Cable Management.

Options: Privacy screen • LockBox • Casters • Tasklight brackets • MemoBoard • Additional shelves • Cable wrap • Need something you don't see - we'll make it.

BullPen

BullPen Configuration

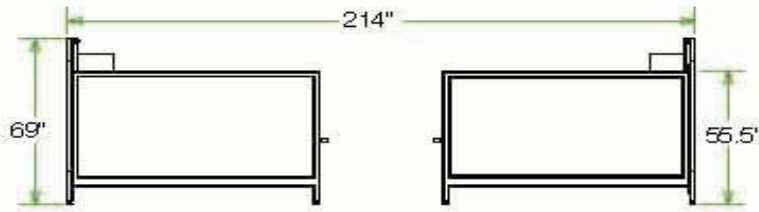
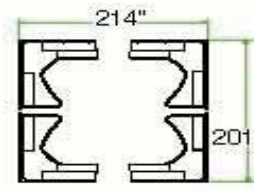
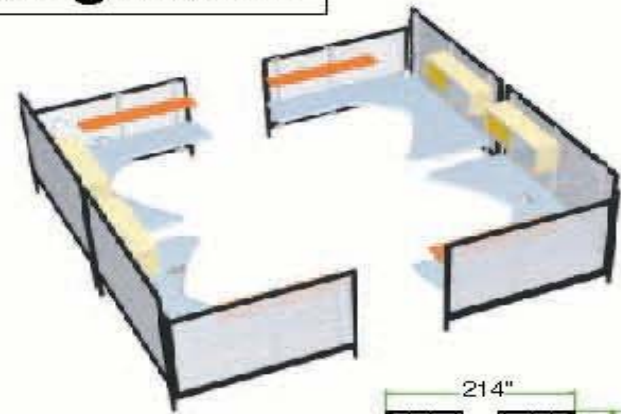

1 Call this work configuration the think tank. It's a contained workspace for four, with adjustable desk and shelving height for each. A space-efficient setting that thrives on teamwork. There is no substitute.

Standard: Monolithic top finished in semi-matte plasticolor enamel • All color options available • Super duty frame with dark grey crinkle powdercoat finish • 4" shelf • Polycarbonate panels • Stainless steel leveling feet • Edge bumper • Adjustable height on all worktops and shelves • Cable Management.

Options: Privacy screen • LockBox • Casters • Tasklight brackets • MemoBoard • Additional shelves • Cable wrap • Left or Right Handedness (Left has the deep side for your monitor on the left) • Need something you don't see - we'll make it.



Z_Grouppo



Info: **Stole flexibility** A serious full service work environment with adjustable desk and shelving height.

Standards: Monolithic top finished in semi-matte plasticolor enamel - All color options available - Super duty frame with dark grey crinkle powdercoat finish - 4" shelf - Polycarbonate panels - Stainless steel leveling feet - Edge bumper - Adjustable height on all worktops and shelves - Cable Management

Options: Privacy screen - LockBox - Casters - Tasklight brackets - MemoBoard - Additional shelves - Cable wrap - Left or Right Handedness (Left has the deep side for your monitor on the left) - Need something you don't see - we'll make it.



MobileStation

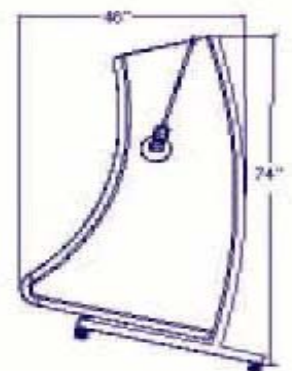
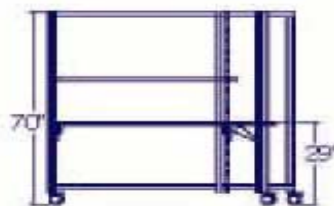

Info: Roll this one in. Perfect for the visiting client or sales team on the go. An ideal design+cost+space efficiency. Elegant/minimal design, sweeping curvilinear shape, mobility and privacy.

Standards: Monolithic top finished in semi-matte plasticolor enamel - Choose your colors - Super duty frame with dark grey crinkle powdercoat finish - 4" Shelf - Polycarbonate panels - Edge Bumper - 4" locking industrial grey and white casters

Options: Privacy Screen - LockBox - DataGrommet - Height - Tasklight - Brackets - MemoBoard - Additional Shelves - Left or Right Handedness (Left has the deep side for your monitor on the left) - Cable Management - Need something you don't see - we'll make it.



Accessories and Colors



Data Grommets

- 1 Anodized brushed aluminum grommet. Add to any workstation.



Shelves

- 1 Additional 4' and 8' shelves available. 11.75" deep.



Lamp Brackets

- 1 For hanging Artemide task lamp on any workstation.



Privacy Screen

- 1 Acoustically engineered blanket framed in powder coated steel designed for privacy and sound reduction. Attaches to any workstation.



Lock Box

- 1 Locking storage unit with sliding doors. Fabricated in wood, aluminum and phenolic resin. Attaches to workstations to hide your books, binders, etc. Master keyable with larger orders.



Memo Board (2 pcs)

- 1 Powder coated steel magnetic board and pen trough attached to translucent laminated glass. Use with dry erase makers.



Black



Yellow



Orange



Eggshell



Natural



Green



BlueGrey



Big Blue



New Green

Materials

- 1 Work surfaces are made from Trupan with semi matte Plasticolor enamel finish. Super duty frame is heavy 10-gauge steel with crinkle grey powdercoat finish. Wheels are cast aluminum chromed with steel hubs.

Shipping

- 1 SWERVE furniture is shipped fully assembled and blanket wrapped (with the exception of Studio Tables and workstations. Crating available upon request.

Special Services

- 1 SWERVE can mass customize tables and workstations: what does this mean? – if you have a large order and specific design needs to fulfill – we can do it. SWERVE is fast.

SWERVE stands behind (in front and on top of) our furniture.



Acoustic Blanket

Privacy Screens

Acoustically engineered blanket framed in powder coated steel. Designed for privacy and sound reduction. Attaches to any workstation.

Movable Screens



SWERVE



SWERVE X-GROUPPO DESIGNED BY MICHAEL GOLDIN
EVOLVE SOFTWARE, EMERYVILLE, CA.

SWERVE

SWERVE

_furniture design factory

BEST OF THE BAY! 2001



*SWERVE... " has
some of the best
workstations, and
well-proportioned
furniture systems..."*

*- San Francisco Chronicle Magazine
and The American Institute of Architects
2000/2001 Interior Award Winner*

WORLD CLASS

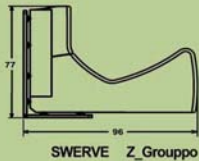

SWERVE Z_Grouppo



Please contact us for your furniture projects at swerveco.com

Photography: Ethan Kaplan

2332 5th street, berkeley, ca 94710
tel 1.510.644.1898 1.877.644.1898
tel 1.510.644.0724



SWERVE

digital business_Furniture design company

INTRODUCES CNC MACHINE

SWERVE is pleased to announce the acquisition of a 5-Axis simultaneously controlled CNC MACHINE. This "Super Machine" is equipped with Automatic Tool Changing for both vertical Routers and Drills. It is a state of the art High-Speed Machining Tool.

This machine can be used for routing, cutting, drilling, model forming and highly accurate, highly efficient finishing of a wide variety of materials including wooden materials, resins, gypsum, styro-foam, etc. Intricate details are possible in wood, nonferrous and composite materials.

We are set up to do 3-D custom work and can machine individual parts as large as 5' x 10' x 3'. Our design process begins in our 3D CAD/CAM UNIGRAPHICS software (developed by McDonnell Douglass) which we then use both for conceptualization and photo realistic modeling/rendering. The complete process, from design to manufacturing, is accomplished rapidly and with amazing accuracy (4/1000").

Please contact us for your jobs or design projects at www.swerveco.com

2332 5th street, berkeley, ca 94710
tel 1.510.544.1898 1.877.544.1898
fax 1.510.544.0724

WORLD CLASS



LG WILLIAMS's place among the great emerging artists of this decade is firmly established. This artwork, designed to accompany his aesthetic beliefs and lectures on art, show conclusively that LG's work is remarkably original, versatile and compelling - and always focused upon what matters most. Whatever the subject, he addresses it with an artist's resonant sophistication, a scholar's precision, and the powers of a great sports athlete. LG teaches at the University of California and California College of Arts and Crafts.

First Class

dai bak hap gallery
po box 26
berkeley, ca 94701
www.daibakhap-gallery.web-page.net



LG WILLIAMS WOULD LIKE TO EXPRESS HIS APPRECIATION TO THE FOLLOWING GROUPS AND ORGANIZATIONS:

Aqua Lube, Los Angeles, CA.
dai bak hap Gallery, Berkeley, CA.
California Arts Council, Sacramento, California.
Hi Gallery, Waikiki, HI.
Kimono Condoms, Oakland, CA.
miracle gallery, Beverly Hills, CA.
National Endowment For The Arts, Washington, DC.
Sierra Nevada Brewing Company, Chico, CA.
Speedo, London, England.
The Eileen and Peter Norton Collection, Los Angeles, CA.

TO:



in conjunction with Yerba Buena's Center For The Arts Upcoming Exhibition
"TO PROTECT AND SERVE"
Jul 26 - Oct 5, 2003

LINC ART SECURITY SERVICES, LTD.
Charles Linder and LG Williams

SECURITY

APPEARANCE AND PERFORMANCE AT
THE YERBA BUENA CENTER FOR THE ARTS
Fri, Jul 25, 8-11 pm • Grand Lobby & Galleries
Sponsored by Lincart, SF, CA; Cashcowboy.com; and The Estate of LG Williams

Yerba Buena
Center for the Arts

Copyright © 2003 Charles Linder and LG Williams
Photograph: Gretchen LaMaistre

115 PAGE CATALOGUE AVAILABLE www.lincart.com www.lg.web-page.net



"Covering Your Ass Since '69"

LINCART SECURITY SERVICES, Ltd.

1632 C Market Street

San Francisco, CA 94103

415-503-1981

www.lincartsecurityservices.web-page.net

Charles Linder, Proprietor

LG Williams, Chief Security Officer

Covering Your Ass Since '69 (YERBA BUENA CENTER FOR THE ARTS – 2003), is an ongoing series of artworks by Charles Linder and LG Williams. This project marks the second appearance/performance in a series of extraordinary artists' projects that might not otherwise be supported by more conventional institutions. For this piece, Linder and Williams re-examine their life-long fascination with questions surrounding protection, nurturing, love, and the accidental – along with their ongoing practice of exploring newly-emerging issues, such as masculinity, historical/national security and the protection of the artwork/artistic species. Charles and LG will create a "Dynamic Super-Homie Security Force" which will evoke and investigate the conventions, covert structures, and serendipities found and hidden "en masse". Due to the very sensitive nature of this highly secretive and artistic project, the artists request that no photographs are to be taken. All images and documentation (card included) of this project are property and copyrighted © 2003 Charles Linder, LG Williams, LincArt, Cashcowboy, and The Estate of LG Williams. For more information about Linder and Williams please visit www.cashcowboy.com and www.lg.web-page.net, respectively.

A Very Special Thanks To Dina Pugh and Gretchen, Catherine, Molly, Megan, Teresa and Evelyn

THIS IS A LIMITED EDITION ARTWORK. PLEASE DO NOT RESELL THIS CARD UNTIL YOU HAVE FIRST PAID FOR IT.

Charles Linder

LG Williams





Bullpen



Copyright © 2000 by [illegible]



My favorite table?

Over 1000 different designs
and more than 1000 different colors

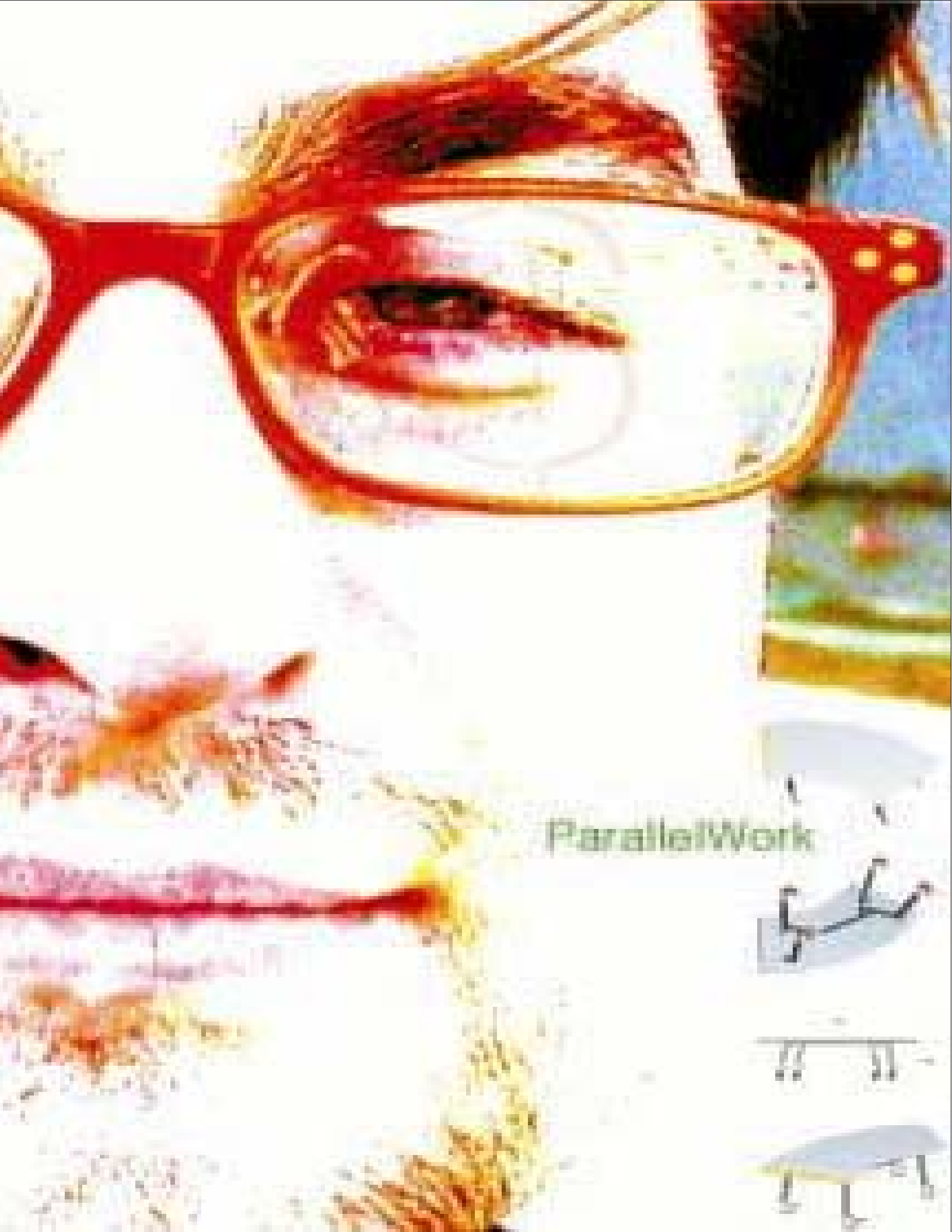

ParallelWork

